

WMU836-N

# CHAIN DRIVE ACTUATOR 24V

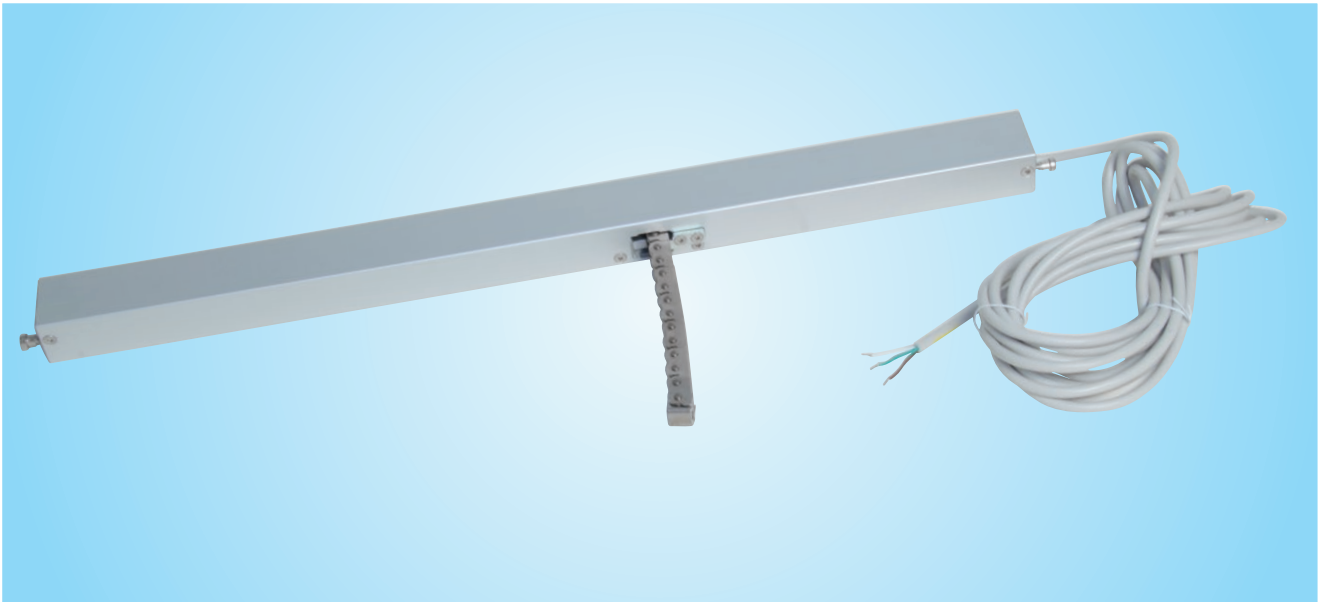

## Description

- designed for surface mounting
- for smoke and comfort ventilation
- approved according to EN 12101-2 with selected profiles please contact Smoke Control Solutions Ltd for further information
- complete opening of the window within 60 sec. (depending on the programming)
- to be used with all window types
- to be used together with  $\pm 24V$  control units or control units with MotorLink™
- can be used together with espagnolette WMB
- synchronization of up to four window actuators – no need for an external synchronization module
- genuine position feedback and three speeds when using control unit with MotorLink™
- soft close function
- the electronics in this actuator can be programmed to suit specific requirements – i.e. pressure and traction force, stroke, speed/sound level – with the WAT 100 programming box, also possible following installation
- built-in electronic load switch-off/end stop
- electronic actuator with micro controller
- the actuator has an integrated reverse function to ensure a prolonged life span of the window gaskets
- easy mounting

## Actuator variants

The actuator is available in four different versions: single WMX 836-1, double WMX 836-2, triple WMX 836-3 and quad WMX 836-4.

The actuators are equipped with a patented synchronization function, in which the actuators communicate directly with each other, which ensures the actuators operate at exactly the same speed and position. On large windows up to four actuators can be mounted on the same window – with no need for an external synchronization module.

## Pressure safety function

The risk of entrapment is reduced as the actuators are programmed to reverse if they encounter obstacles when closing. The set points determining when the actuators are to reverse are individually adjustable and can be adjusted after installation using the programming box WAT 100.

## Opening speeds

Actuators connected to  $\pm 24$  VDC control units (e.g. WUC) have one chain speed – see the following page for opening speed.

Actuators connected to control units with MotorLink™ (e.g. WSC xxM) have three different speeds:

- slow speed by soundless automatic control of the windows
- faster speed by audible manual (keypads) control of the windows
- fast speed by smoke ventilation and security functions

# CHAIN DRIVE ACTUATOR 24V

Specifications	
Compressive force	see diagram
Tractive force	300N
Locking force	3000N
Chain stroke	400, 600, 800 and 1000mm
Opening speed	11mm/s (programmable up to 14mm/s)
Window types	tophung, bottomhung, pivot and turning window vent size should be confirmed with the window supplier and Smoke Control Solutions Ltd
Nominal voltage	24 VDC (max. 10% ripple)
Voltage	20 - 36 VDC
Open circuit voltage	max. 36 VDC
Current consumption	max. 1,0A
Consumption of power	max. 24W
Operating conditions	-5°C - +74°C, max. 90% relative humidity (not condensing)
Switch-on-duration	ED 40% (max. 4min. per 10min)
Material	anodised aluminium housing with stainless steel chain actuator delivered with 5m grey silicone cable 3-cores 0.75m <sup>2</sup>
Colour	anodized aluminium, other RAL colours available at an additional price
Size	34 x 47mm (H x D), length (L) depending on chain stroke – see table
Weight	400mm: 2.2kg, 600mm: 2.6kg, 800mm: 3.0kg, 1000mm: 3.4kg
IP rating	IP32
Fire test	tested according to DIN 18232-3, part 3.6 (30 min./300°)
Life span	tested with 10,000 opening and closing movements
Delivery includes	Europe: actuator with 5m cable
To be ordered separately	actuator bracket and chain bracket
Note	we reserve the right to make technical changes

Items	Chain stroke [mm]	Compressive force [N] *(only bottom hung window)	Length (L) [mm] (incl. screws = 18mm)	Item no.
Single actuator	400	300	568	WMU 836-1 0400
	600	300	668	WMU 836-1 0600
	800	0*	768	WMU 836-1 0800
	1000	0*	868	WMU 836-1 1000
Double actuator	400	300	568	WMU 836-2 0400
	600	300	668	WMU 836-2 0600
	800	0*	768	WMU 836-2 0800
	1000	0*	868	WMU 836-2 1000

Smoke Control Solutions Ltd - Faraday Court, Faraday Road, Crawley, West Sussex RH10 9PU

Tel: 0845 500 9000 Fax: 0845 500 7000

Email [info@smokecontrolsolutions.com](mailto:info@smokecontrolsolutions.com) - Web: [www.smokecontrolsolutions.com](http://www.smokecontrolsolutions.com)

# CHAIN DRIVE ACTUATOR 24V

Items	Chain stroke [mm]	Compressive force [N] *(only bottom hung window)	Length (L) [mm] (incl. screws = 18mm)	Item no.
Triple actuator	400	300	568	WMU 836-3 0400
	600	300	668	WMU 836-3 0600
	800	0*	768	WMU 836-3 0800
	1000	0*	868	WMU 836-3 1000
Quad actuator	400	300	568	WMU 836-4 0400
	600	300	668	WMU 836-4 0600
	800	0*	768	WMU 836-4 0800
	1000	0*	868	WMU 836-4 1000

Accessories	Item no.
Shortening electronically of chain	WKK 836
Actuator bracket for WMU 836 / 936 / 866	WAB 836A
Actuator bracket for WMU 836 / 936 / 866	WAB 836B
Chain bracket for WMU 836 / 936	WAB 836E
Chain bracket for WMU 836 / 936	WAB 811
Actuator bracket for WMU 836 / 936	WAB 812
Actuator bracket for WMU 836	WAB 824
Z-Bracket for inward opening windows	WAB 825

## Installation suggestion 1

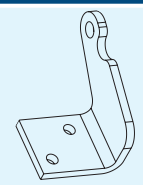
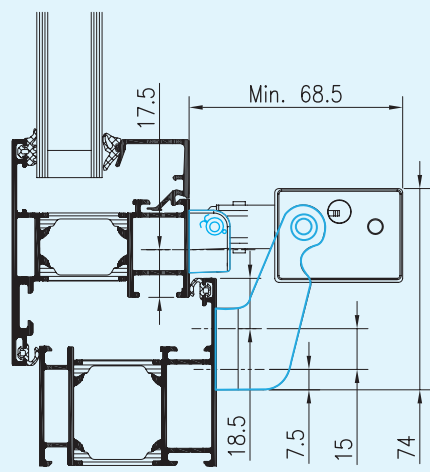

WAB 836B

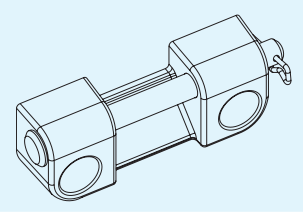

WAB 836E

# CHAIN DRIVE ACTUATOR 24V

## Installation suggestion 2

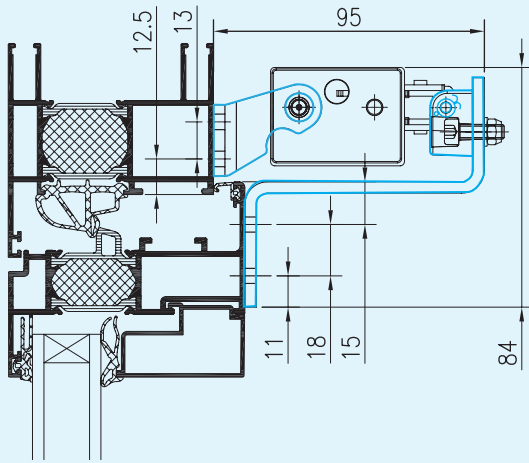

WAB 824

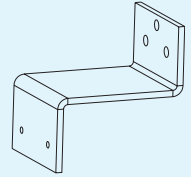

WAB 825

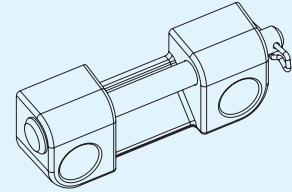

WAB 836E

## Installation suggestion 3

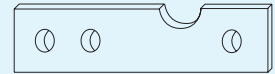
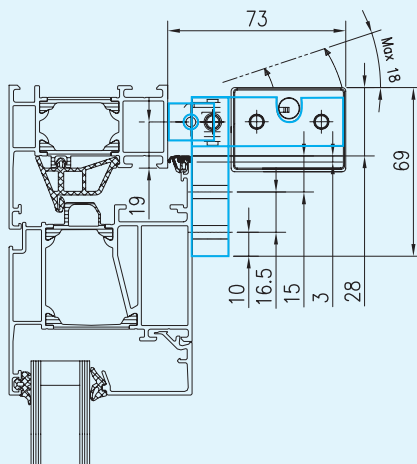

WAB 812

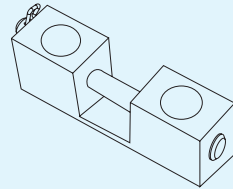
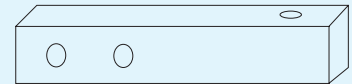

WAB 811

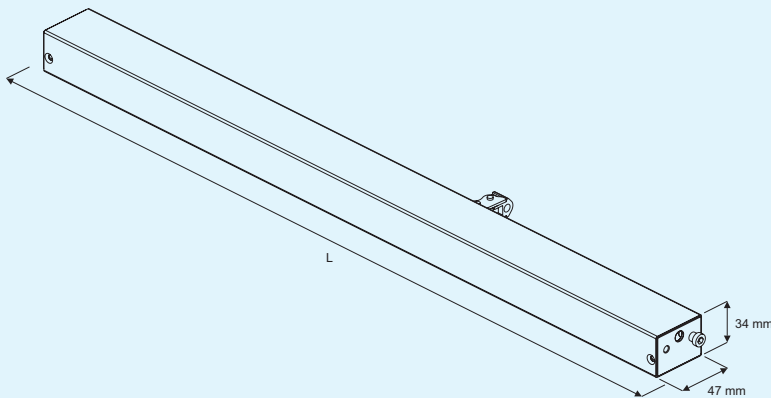

L = Length (incl. screws) – see table of items

